



AN-07 LASER DIODES IN THE 9mm PACKAGE

The package must be in good thermal contact with a heatsink capable of dissipating the heat generated by the laser. For best results, the heatsink should be made from a good heat conductor such as Copper or Aluminum. The heatsink surface where it contacts the base of the laser package should be machined flat and smooth to enable efficient heat transfer. Also, this surface must be flat so that the package is not distorted when the clamp is tightened.

If an Aluminum heatsink plate is used, the Aluminum should not be anodized in the area where the base of the laser contacts the heatsink plate. A thick anodized layer is a good thermal insulator. The heatsink must contact as much of the package base as possible for efficient heat removal. Heat cannot be removed from the laser through the lid of the package because it is made of thin steel and cannot efficiently conduct heat.

*****IMPORTANT***** The entire base of the 9.0 mm package is made from pure Copper for efficient heat transfer. But Copper is very soft, and excessive or uneven clamping force can damage the laser or compromise the hermetic seal.

Standard 9mm pinout:

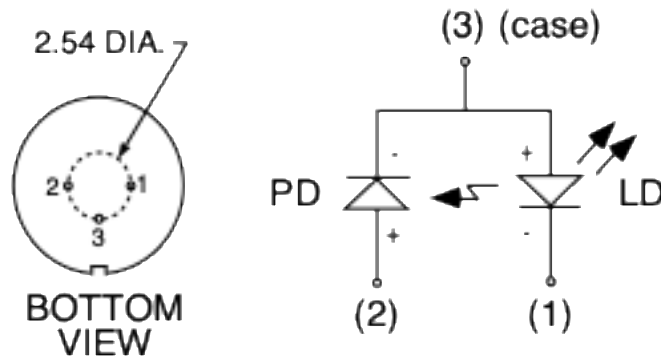

9mm package mounting suggestion:

