



PART NUMBER 0505L-11A
 ITEM NAME 505 NM LASER (DIODE; FREE-SPACE)

PRODUCT DATASHEET



DESCRIPTION

Green laser sources are often used for fluorescence excitation, Raman scattering, as well as for Ti:sapphire pumping applications. High long-term power stability is ensured by TEC thermal stabilization, thermal and optical feedback.

SPECIFICATIONS

Specifications updated: 11 May 2021

Parameter	Minimum Value	Typical Value	Maximum Value
Central Wavelength, nm	500	505	510
Longitudinal modes	-	Multiple	-
Spectral line width FWHM, nm	0.02	0.7	2
Output power, mW	-	60 ¹	70
Power stability, % (RMS, 8 hrs)	0.02	0.03 ²	0.5
Power stability, % (peak-to-peak, 8 hrs)	0.1	0.15 ³	1
Intensity noise, % (RMS, 20 Hz to 20 MHz)	0.1	0.5 ⁴	1
Transversal modes	-	TEM ₀₀	-
Beam width (1/e ²), mm	-	0.9 ⁵	1.6
Beam height (1/e ²), mm	-	1.3	2
Horizontal beam divergence, mrad	-	0.8	1.2
Vertical beam divergence, mrad	-	0.5	1
M ² horizontal axis	-	1.1	1.4
M ² vertical axis	-	1.2	1.5
M ² effective	-	1.2	1.5
Polarization direction	-	Horizontal ⁶	-
Polarization contrast	1000	2000	5000
Control interface type	-	UART ⁷	-
Operation mode	-	APC (CW)	-
Modulation bandwidth, MHz	-	10 ⁸	-
Input voltage, VDC	4.8	5	5.3
External power supply requirement	-	+5 V DC, 1.5 A	-
Dimensions, mm	-	50 x 30 x 18 ⁹	-

TYPICAL SPECTRUM

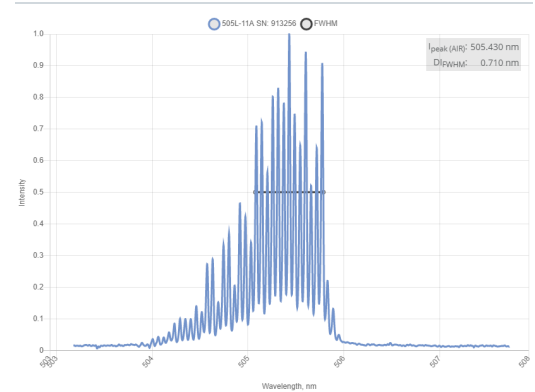

Typical spectrum of 0505 nm diode laser. Measured with 20 pm resolution.

DRAWING

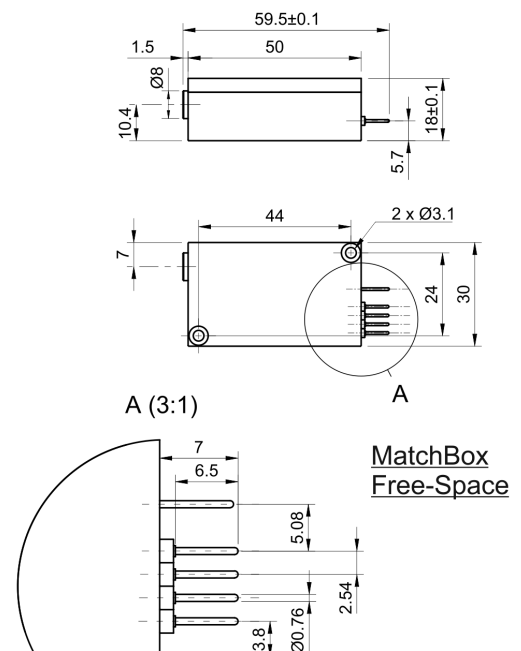

Beam height from the base, mm	9.9	10.4	10.9
Heat-sinking requirement, °C/W	-	1	-
Optimum heatsink temperature, °C	15	20	30
Warm up time, mins (cold start)	0.1	0.5	1
Temperature stabilization	-	Internal TEC	-
External fan control	-	No ¹⁰	-
Overheat protection	-	Yes	-
Storage temperature, °C (non-condensing)	-10	-	+50
Net weight, kg	0.1	0.12	0.14
Max. power consumption, W	0.4	2	10
Warranty, months (op. hrs)	-	14 (10000) ¹¹	-
RoHS	-	Yes	-
CE compliance	-	- General Product Safety Directive (GPSD) 2001/95/EC - (EMC) Directive 2004/108/EC	-
Laser Safety Class	-	3B	-
OEM lasers are not compliant with (compliant using additional accessories)	-	IEC60825-1:2014 (compliant using additional accessories)	-
Country of origin	-	Lithuania	-

¹ The optical power can be tuned from virtually 0% to 100%. However, other specifications, such as central wavelength, power stability, noise, polarization ratio, beam shape, quality and circularity are not guaranteed at power levels other than factory preset power. Significantly worse power stability is to be expected at very low power levels, e.g. <3% from specified nominal power.

² The long term power test is carried out at constant laser body temperature (+/-0.1 °C) using an optical power meter with an input bandwidth of 10 Hz. The actual measurement rate has a period of about 20 seconds to 1 minute.

³ The long term power test is carried out at constant laser body temperature (+/-0.1 °C) using an optical power meter with an input bandwidth of 10 Hz. The actual measurement rate has a period of about 20 seconds to 1 minute.

⁴ Noise level is measured with a fast photodiode connected to an oscilloscope. The overall system bandwidth is from 2 kHz to 20 MHz.

⁵ Beam width and height are measured at 0.45 m from output aperture.

⁶ For lasers without optical isolators.

⁷ Break-out-boxes AM-C8 and AM-H10 can be used for the conversion of UART communication to either USB or RS232.

⁸ TTL digital modulation up to 10 MHz. If fan control is needed, the modulation function must be disabled at the hardware level.

⁹ Excluding control interface pins and an output window/fiber assembly.

¹⁰ This function can be enabled in hardware only if the fast modulation option is disabled. The customer must specify this before ordering the laser.

¹¹ Whichever occurs first. The laser has an integrated operational hours counter.

Note: Product specifications are subject to change without prior notice to improve reliability, function or design or otherwise.