

DATA SHEET

NEC

LASER DIODE NX8562LB

1 550 nm CW LIGHT SOURCE InGaAsP STRAINED MQW-DFB LASER DIODE MODULE

DESCRIPTION

The NX8562LB is a 1 550 nm laser diode with Polarization Maintain Fiber (PMF).

This device is designed as CW light source and ideal for transmission systems in which external modulators are used.

FEATURES

- Output power $P_f = 20 \text{ mW MIN.}$
- Wavelength selectable for ITU-T standards
- Internal thermo-electric cooler and isolator
- Hermetically sealed 14-pin butterfly package
- Polarization maintain fiber pigtail

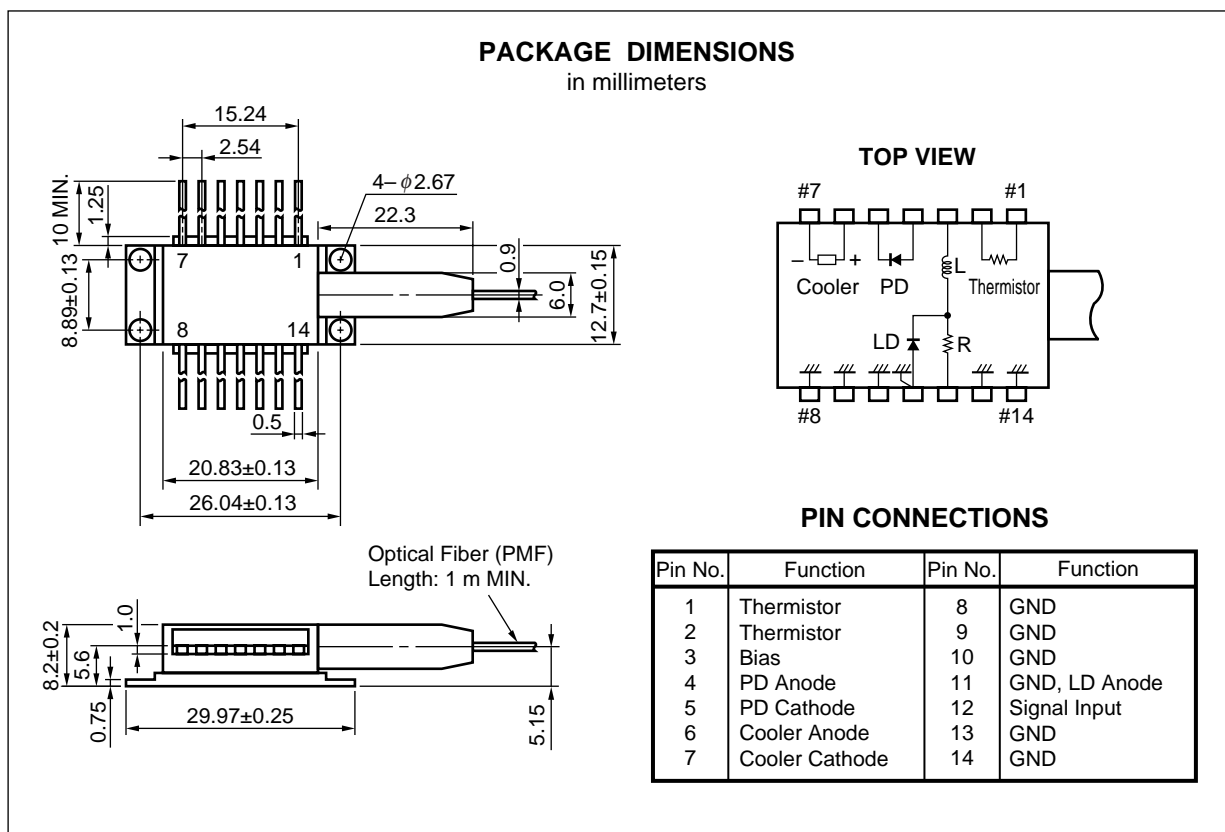

The information in this document is subject to change without notice.

★

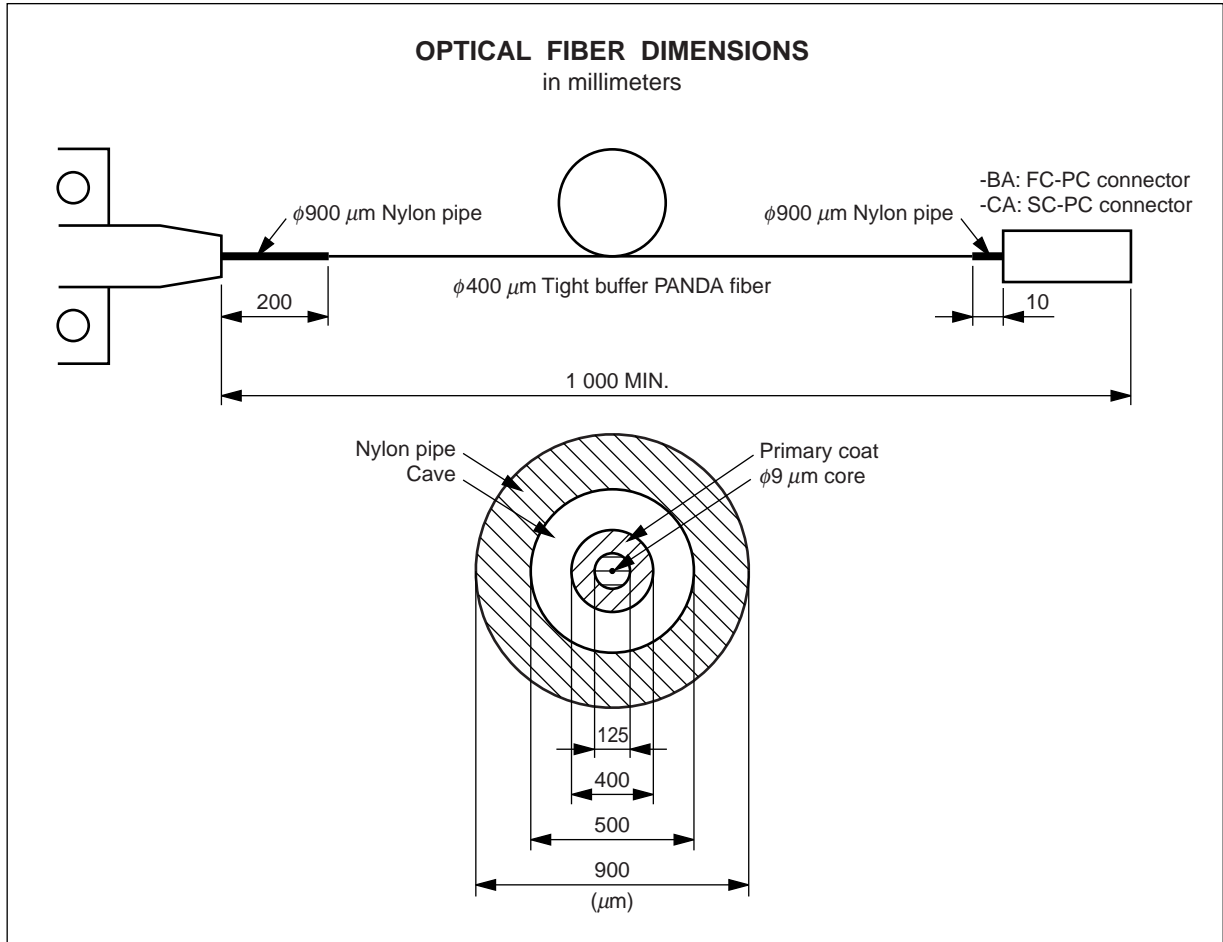

ORDERING INFORMATION

Part Number	Available Connector
NX8562LB	Without Connector
NX8562LB-BA	With FC-PC Connector
NX8562LB-CA	With SC-PC Connector

ABSOLUTE MAXIMUM RATINGS (T_c = 25 °C, unless otherwise specified)

Parameter	Symbol	Ratings	Unit
Forward Current of LD	I _F	300	mA
Reverse Voltage of LD	V _R	2.0	V
Forward Current of PD	I _F	10	mA
Reverse Voltage of PD	V _R	20	V
Operating Case Temperature	T _c	-20 to +65	°C
Storage Temperature	T _{stg}	-40 to +85	°C
Lead Soldering Temperature (10 s)	T _{slid}	260	°C

ELECTRO-OPTICAL CHARACTERISTICS (T_{LD} = 25 °C, T_c = -20 to +65 °C)

Parameter	Symbol	Conditions	MIN.	TYP.	MAX.	Unit
Laser Set Temperature	T _{set}		20		35	°C
Forward Voltage	V _F	P _f = 20 mW	0.9		1.5	V
Threshold Current	I _{th}			20	40	mA
Optical Output Power from Fiber	P _f	I _F = 167 mA, T _{LD} = T _{set}	20			mW
Threshold Output Power from Fiber	P _{th}	I _F = I _{th}			100	μW
Quantum Efficiency	η		0.13			W/A
Peak Emission Wavelength ^{*1}	λ _p	P _f = 20 mW, CW, T _{LD} = T _{set}	1 540		1 561	nm
Spectral Line Width	Δν	P _f = 20 mW, CW, 3 dB down		1	2	MHz
Side Mode Suppression Ratio	SMSR	P _f = 20 mW, CW	30	35		dB
FM Response	η _{FM}	P _f = 20 mW	50	70		MHz/mA
Relative Intensity Noise	RIN	P _f = 20 mW, 20 MHz to 3 GHz			-150	dB/Hz
Flat frequency response	f _m	P _f = 20 mW, +/-3 dB	1.8			GHz
Polarization Extinction Ratio ^{*2}	ext	P _f = 20 mW, CW	15	20		dB

*1 Wavelength selectable for ITU-T standards.

*2 Polarization state of LD is aligned parallel to the slow axis.

ELECTRO-OPTICAL CHARACTERISTICS

(Applicable to Monitor PD: $T_{LD} = 25\text{ °C}$, $T_c = -20\text{ to }+65\text{ °C}$)

Parameter	Symbol	Conditions	MIN.	TYP.	MAX.	Unit
Monitor Current	I_m	$P_f = 20\text{ mW}$, $V_R = 5\text{ V}$	100			μA
Dark Current	I_D	$V_R = 5\text{ V}$		2	10	nA
Tracking Error	γ^{*1}	$I_m = \text{const.}$			0.5	dB

$$*1 \gamma = \left| 10 \log \frac{P_f}{20\text{ mW}} \right|$$

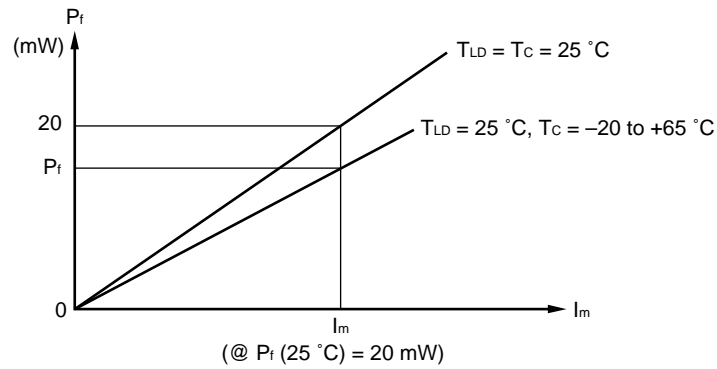

ELECTRO-OPTICAL CHARACTERISTICS

(Applicable to Thermistor and TEC: $T_{LD} = 25\text{ °C}$, $T_c = -20\text{ to }+65\text{ °C}$)

Parameter	Symbol	Conditions	MIN.	TYP.	MAX.	Unit
Thermistor Resistance	R	$T_{LD} = 25\text{ °C}$	9.5	10.0	10.5	$\text{k}\Omega$
B Constant	B		3 300	3 400	3 500	K
Cooler Current	I_c	$\Delta T = 65 - T_{set}$, $P_f = 20\text{ mW}$			1.0	A
Cooler Voltage	V_c	$\Delta T = 65 - T_{set}$, $P_f = 20\text{ mW}$			2.0	V

DFB-LD FAMILY FOR TELECOM

Part Number	Absolute Maximum Ratings		Typical Characteristics			SDH Application	Package
	T _c (°C)	T _{stg} (°C)	I _{th} (mA)	P _r (mW)	λ _p (nm)		
			TYP.	MIN.	TYP.		
NDL7603P Series	-40 to +85	-40 to +85	15	2	1 310	≤ STM-4 : 622 Mb/s	Coaxial
NDL7620P Series	0 to +70	-40 to +85	45 (MAX.)	2	1 310	≤ STM-16: 2.5 Gb/s	Coaxial
NDL7701P Series	-20 to +85	-40 to +85	15	2	1 550	≤ STM-4 : 622 Mb/s	Coaxial
NDL7705P Series	-40 to +85	-40 to +85	15	2	1 550	≤ STM-4 : 622 Mb/s	Coaxial
NX8562LB	-20 to +65	-40 to +85	20	20	1 550 ^{*1}	CW Light Source for external modulator	BFY
NX8563LB Series	-20 to +65	-40 to +85	20	10	ITU-T ^{*2}	CW Light Source for external modulator	BFY
NDL7910P	-20 to +70	-40 to +85	7	0.5	1 550 ^{*1}	≤ STM-16: 2.5 Gb/s EA modulator integrated DFB-LD	BFY

*1 Wavelength selectable for ITU-T standards upon request.

*2 Wavelength selectable for ITU-T standards.

REFERENCE

Document Name	Document No.
NEC semiconductor device reliability/quality control system	C11159E
Quality grades on NEC semiconductor devices	C11531E
Semiconductor device mounting technology manual	C10535E
Semiconductor selection guide	X10679E

[MEMO]

CAUTION

Within this device there exists GaAs (Gallium Arsenide) material which is a harmful substance if ingested. Please do not under any circumstances break the hermetic seal.

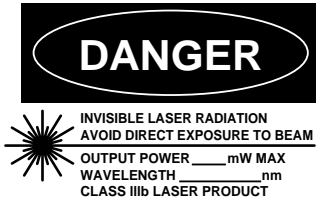

SEMICONDUCTOR LASER

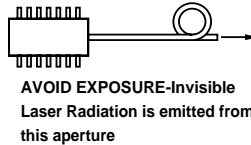

NEC Corporation
 NEC Building, 7-1, Shiba 5-chome,
 Minato-ku, Tokyo 108-01, Japan

Type number: _____
 Manufactured: _____
 Serial Number: _____

This product conforms to FDA
 regulations as applicable
 to standards 21 CFR Chapter 1.
 Subchapter J.

The export of this product from Japan is prohibited without governmental license. To export or re-export this product from a country other than Japan may also be prohibited without a license from that country. Please call an NEC sales representative.

No part of this document may be copied or reproduced in any form or by any means without the prior written consent of NEC Corporation. NEC Corporation assumes no responsibility for any errors which may appear in this document.

NEC Corporation does not assume any liability for infringement of patents, copyrights or other intellectual property rights of third parties by or arising from use of a device described herein or any other liability arising from use of such device. No license, either express, implied or otherwise, is granted under any patents, copyrights or other intellectual property rights of NEC Corporation or others.

While NEC Corporation has been making continuous effort to enhance the reliability of its semiconductor devices, the possibility of defects cannot be eliminated entirely. To minimize risks of damage or injury to persons or property arising from a defect in an NEC semiconductor device, customers must incorporate sufficient safety measures in its design, such as redundancy, fire-containment, and anti-failure features.

NEC devices are classified into the following three quality grades: "Standard", "Special", and "Specific". The Specific quality grade applies only to devices developed based on a customer designated "quality assurance program" for a specific application. The recommended applications of a device depend on its quality grade, as indicated below. Customers must check the quality grade of each device before using it in a particular application.

Standard: Computers, office equipment, communications equipment, test and measurement equipment, audio and visual equipment, home electronic appliances, machine tools, personal electronic equipment and industrial robots

Special: Transportation equipment (automobiles, trains, ships, etc.), traffic control systems, anti-disaster systems, anti-crime systems, safety equipment and medical equipment (not specifically designed for life support)

Specific: Aircrafts, aerospace equipment, submersible repeaters, nuclear reactor control systems, life support systems or medical equipment for life support, etc.

The quality grade of NEC devices is "Standard" unless otherwise specified in NEC's Data Sheets or Data Books. If customers intend to use NEC devices for applications other than those specified for Standard quality grade, they should contact an NEC sales representative in advance.

Anti-radioactive design is not implemented in this product.

This datasheet has been download from:

www.datasheetcatalog.com

Datasheets for electronics components.